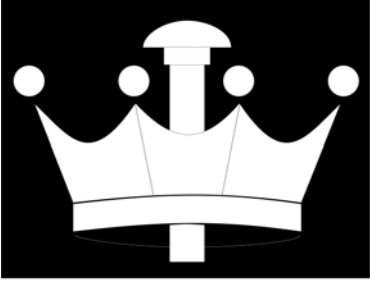


R I V E T



K I N G®

Instruction Manual  
RK-500Q-NP6





## CONTENTS

<b>Safety</b>	<b>Page 3</b>
<b>Specifications</b>	<b>Page 3</b>
<b>Preparing the tool for service</b>	<b>Page 4</b>
<b>Air supply</b>	<b>Page 4</b>
<b>Maintenance</b>	
Daily	<b>Page 5</b>
Weekly	<b>Page 6</b>
Monthly	<b>Page 7</b>
Trigger Service	<b>Page 8</b>
<b>Assembly Drawings</b>	
Schematic	<b>Addendum A</b>
Parts List	<b>Addendum B</b>
<b>MSDS</b>	<b>Page 10</b>
<b>Troubleshooting</b>	<b>Page 12</b>
<b>Warranty</b>	<b>Page 13</b>

## SAFETY

- DO NOT USE OUTSIDE DESIGN INTENT OR WITH EQUIPMENT THAT IS NOT RECOMMENDED BY THE MANUFACTURER.
- ALWAYS DISCONNECT THE AIR SUPPLY BEFORE ATTEMPTING ANY MAINTENANCE OR ADJUSTMENT/FITTING OF NOSE EQUIPMENT
- DO NOT OPERATE A TOOL THAT IS DIRECTED TOWARDS ANY PERSON(S) OR WITH THE NOSE PIECES OFF THE TOOL
- ALL MODIFICATIONS CARRIED OUT ON THE TOOL WITHOUT EXPRESS WRITTEN CONSENT OF THE MANUFACTURER SHALL BE DONE SO AT THE CUSTOMERS' SOLE RESPONSIBILITY
- REFER TO THIS MANUAL BEFORE ATTEMPTING ANY MAINTENANCE OPERATION. DO NOT DISASSEMBLE THIS TOOL BEFORE REFERING TO THIS MANUAL.
- AVOID EXCESSIVE CONTACT WITH HYDRAULIC OIL, AS SOON AS POSSIBLE WASH HANDS THOROUGHLY
- DO NOT EXCEED 6 BAR / 90 PSI INLET PRESSURE, THE USE OF A PRESSURE REGULATOR IS HIGHLY RECOMMENDED
- INSPECT THE TOOL USING PREVENTITIVE MAINTENANCE TECHNIQUES AT REGULARLY SCHEDULED INTERVALS. INSPECT FOR DAMAGE AND FUNCTION BY TRAINED COMPETANT PERSONEL. THE PLASTIC BODY MUST BE CHANGED WHENEVER THERE IS EVIDANEC OF IMPACT DAMAGE, CHIPPING, OR CRACKING.
- WEAR SAFETY GLASSES AND ADOPT FIRM FOOTING DURING OPERATION.

## SPECIFICATIONS

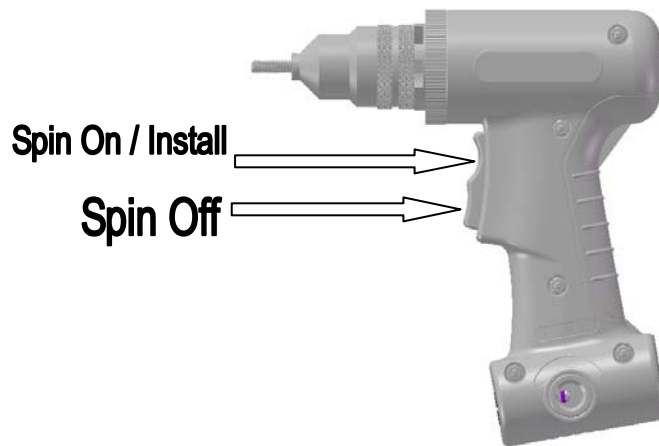
The specifications and information contained in this manual are applicable only to the tool with which it was supplied. Industrial Rivet & Fastener Co reserve the right to make any changes without notice as part of Industrial Rivet & Fastener Co policy of continuous improvement.

### SPECIFICATIONS RIVET NUT TOOL

Air Pressure	Min/Max	□ 5.5 – 6 bar	□ 80-90 psi
Free Air Volume Required	@5.5 bar/75psi	□ 4.3 liters	□
The Tool Come With	NP8	□ 5/16-18 Nose Set	□ All materials
Purchased Separately	NP6	□ ¼-20 Nose Set	□ All materials

## PREPARING THE TOOL FOR SERVICE

1. Inspect for damage
2. Connect the tool to the air supply
3. Insure the Rivet Nut you wish to install is within the capacity of the rivet tool
4. Choose and securely install the applicable nose piece for the rivet nuts you wish to apply.
5. Bring the tool and the rivet into the application hole. Insure the rivet head flat onto surface
6. Fully actuate the rocker trigger. The top button will spin the rivetnut onto the mandrel and install the rivetnut into the workpiece. The lower button will spin the rivetnut off the mandrel.



## JAMMED GUN REMEDY

1. Disconnect tool from air supply
2. Remove Nose Piece
3. Replace Mandrel if Necessary
4. Reapply the nose case securely to the tool
5. Reattach air supply. Actuate tool without rivet. Check Function.
6. Once comfortable, Apply Rivets nuts.

## AIR SUPPLY

- The rivet tool is powered by compressed air at an optimum pressure of 5.5-6.0bar(80-90 psi)
- The use of a pressure regulator filter/lubricator unit within 3 meters of the tool is highly recommended to extend the life of the tool.

**Dirt and/or water in the air supply can seriously impact the performance and durability of the tool; damage to the tool caused by contaminated air supply is not covered under warranty**

## MAINTENANCE

In order to maintain the tool in a safe working order it is important to carry out regular maintenance as prescribed by the manufacturer. A thorough inspection replacement of all seals within the tool should be carried out after 500,000 placings or annually, whichever is the sooner. Item numbers in parentheses refer to assembly drawing part numbers

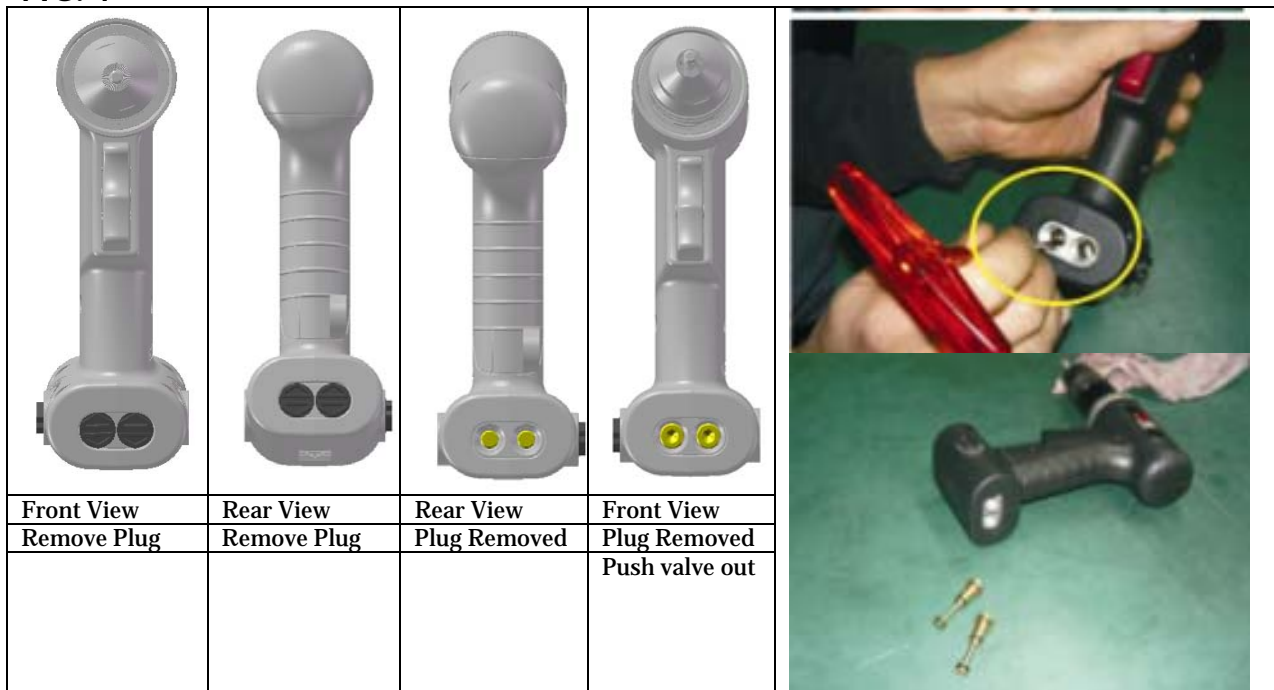
### Daily Maintenance

- Check for air leaks. Any damaged hoses should be replaced
- Lubricate the tool by pouring a few drops of light lubricating oil into the air inlet on the tool
- If there is no pressure regulator, bleed the airline to clear it of accumulated dirt or water before connecting the air hose to the tool. If there is a filter, drain it.
- Check for proper nose piece/mandrel use depending on the size of the rivet nut.
- Remove the mandrel from the front nose assembly and inspect for cracks, wear or other damage. Replace if necessary.
- Check that front nose assembly is fully tightened onto body

## Weekly Maintenance

- Carry out procedures as per daily maintenance instructions above
- Clean and inspect the following using the below procedure..
  - Remove the 4 black screw plugs (2 in the front and 2 in the rear of the tool), exposing the brass pilot valve stem (see Fig 1).
  - With a blow gun, apply a stream of air to the threaded inlet to blow out any excess oil, dirt, or debris. (Fig 2a)
  - Wipe the brass pilot valve stem of excess oil, dirt or debris. Clean in spirits if necessary. Then, with a blow gun, apply a stream of air to the small hole in the center of the pilot valve stem, cleaning them of excess oil, dirt and debris.
  - Apply a generous coating of White Lithium Grease to the O-rings on the valve stem
  - Reassemble the valve stem and plugs insuring that the valve stem is placed in the tool correctly.

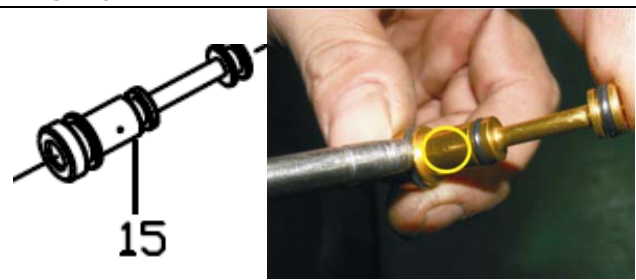
**FIG. 1**



**FIG. 2a**

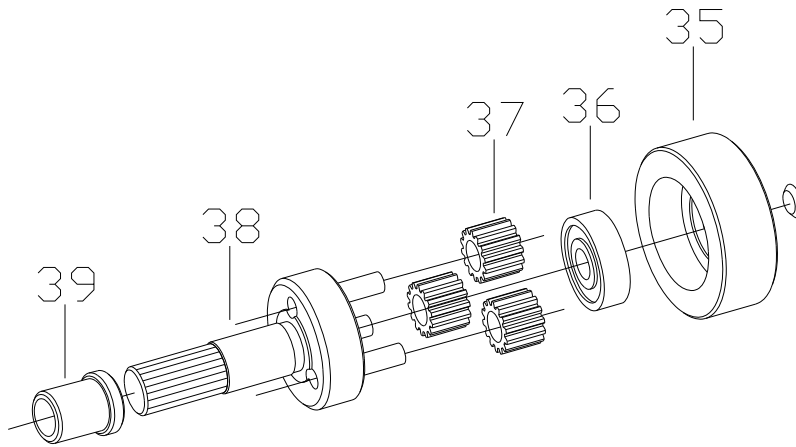


**FIG 2b**



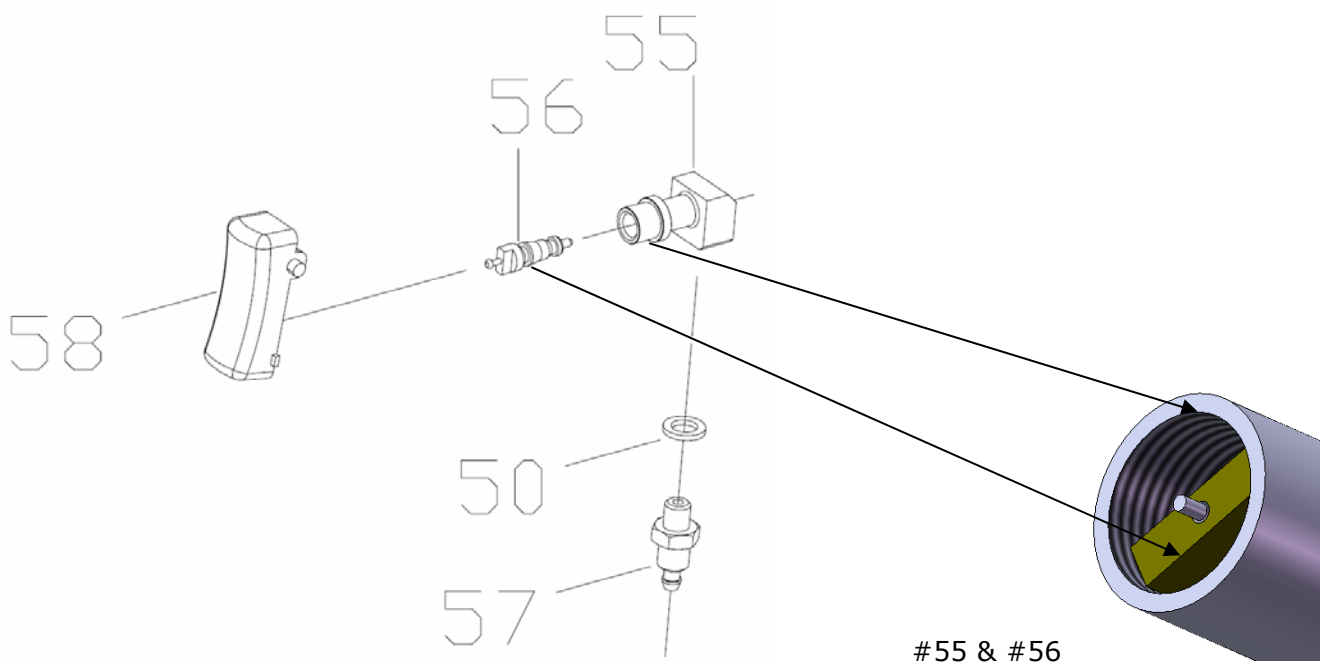
## Monthly Maintenance

- Carry out procedures as per daily & monthly maintenance instructions above
- Grease the engine/gear reducer with a red synthetic grease



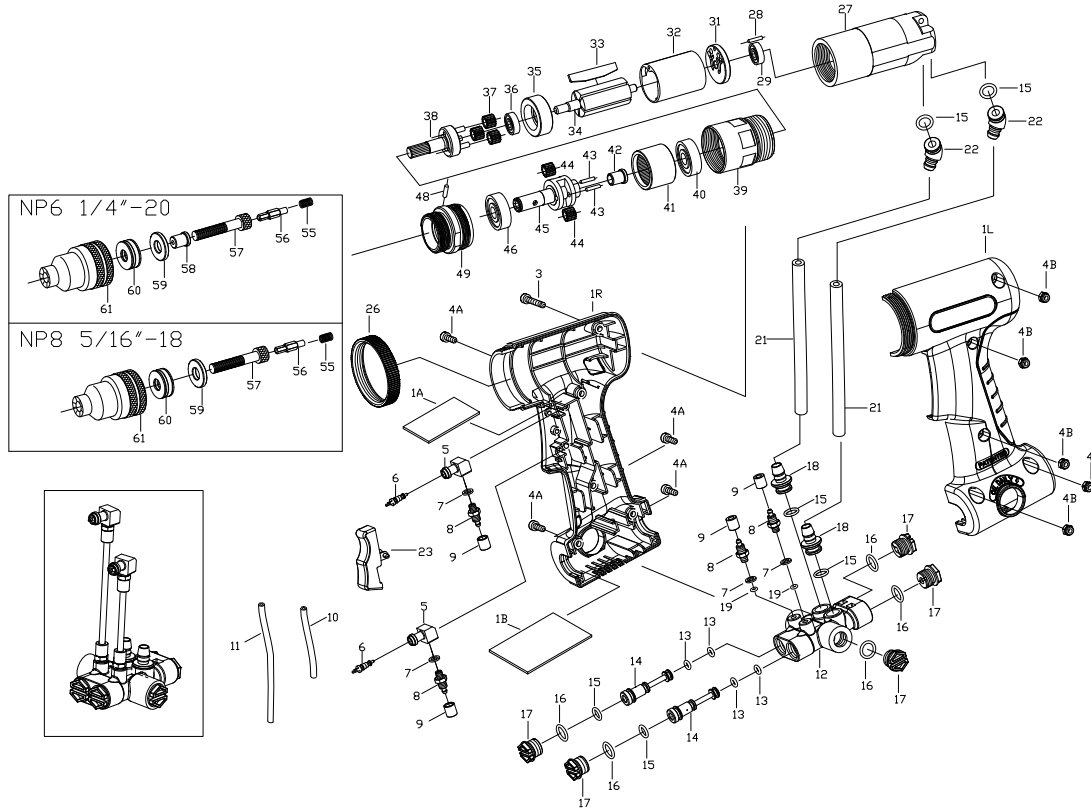
## Trigger Service

- Inspect trigger pin valve by insuring **56** has not come loose. The proper depth should be just under the valve stem.
- If adjustment is necessary using a fork wrench or tire valve tool, screw the trigger pin **56** into the valve stem. A very small amount of loctite243 is ok around the threaded portion only.
- If the trigger still fails, remove the trigger pin assembly from the valve stem and inspect the seal around the trigger pin for damage. If damaged, purchase a replacement part. Re-assemble according to the previous step.





# RK-500Q AIR RIVET NUT TOOL



## RK-500Q AIR RIVET NUT TOOL

<b>TECHNICAL DATA</b>	Capacity:	: 1/4"-20, 5/16"-18 rivet nut in all materials
	Free Speed	: 500 RPM
	Avg. Air Consumption	: 9.2cfm (260 l/min)
	Operating Air Pressure	: 90 PSI (6.2 Bar)
	Length	: 233mm
	Net Weight	: 1.4 kgs
	Air Inlet	: 1/4" NPT/PT
	Hose Size (I.D.)	: 3/8" (9.5mm) I.D.
	Sound pressure	: 95 DBA

### PARTS LIST

Index	Part #	Description	Index	Part #	Description	Index	Part #	Description
1L	180101L-B	Housing-L	19.	OR0306	O-RING (2)	41.	208501	Internal Gear
1R	180101R-B	Housing-R	21.	180702	6x8xL:130 Air Hose(2)	42.	208504	Bushing
1A	180704	Muffler material	22.	180201	Hose Connector Y (2)	43.	RP4015	Pin (2)
1B	180714	Muffler material	23.	461601	Butterfly Trigger	44.	208502	Planet cage (2)
3.	040725	Screw	26.	108102	Lock Nut	45.	208506	Planet cage
4A	040713	Screw (4)	27.	320101	Motor housing	46.	B26001	Ball Bearing
4B	NN0407B	Throttle lever nut(5)	28.	SP2514	Spring Pin	48.	RP2005	Pin
5.	107602	Valve Body (2)	29.	B20626	Ball Bearing	49.	208105	Clamp Housing
6.	107601	Bleeding Valve (2)	31.	320302	End Plate	55.	208507	Spring
7.	612714	Washer (4)	32.	320301	Cylinder	56.	114801	Hexagon Bit 1/4"-20
8.	612717	Socket (Lower) (4)	33.	320305	Rotor Blade (6)		516801	Hexagon Bit 5/16"-18
9.	612711	Cap (4)	34.	320304	Rotor	57.	S142044	Bolt 1/4"-20
10.	180703S	2x4xL:48 Air Hose-S	35.	320303	Front Plate		S516044	Bolt 5/16"-18
11.	180703L	2x4xL:79 Air Hose-L	36.	B20608	Ball Bearing	58.	114802	Bushing #1420
12.	461201	Valve	37.	320502	Planet Gear (3)	59.	106803	Washer (S)
13.	OR0408	O-RING (4)	38.	208503	Planet cage		208803	Washer (M)
14.	919202	Valve Steam (2)	39.	208104	Housing	60.	T21024	Thrust Bearing
15.	OR0711	O-RING (6)	40.	B26002	Ball Bearing	61.	114804	Nut Anvil 1/4"-20
16.	OR1014	O-RING (5)					516804	Nut Anvil 5/16"-18
17.	107409	Inlet Plug (5)						
18.	180202	Hose Connector S (2)						

## **SCHEMATIC**

Please see the attached document for the parts drawing & parts list.

## **PARTS LIST**

Please see the attached document for the parts drawing & parts list.

## **Oil Details**

The recommended oil for priming is Hyspin VG32 available in 0.51 or one gallon containers, or, you can use 30W hydraulic oil. Please see safety data below.

## **Hyspin VG 32 Oil Safety Data**

### **First Aid**

#### **SKIN:**

Wash thoroughly with soap and water as soon as possible. Casual or short term contact requires no immediate attention.

#### **INGESTION:**

Seek medical attention immediately. DO NOT induce vomiting.

#### **EYES:**

Irrigate immediately with water for several minutes. Although NOT a primary irritant, minor irritation may occur following contact.

### **Fire**

Flash point 232°C. Not classified as flammable.

Suitable extinguishing media: CO<sub>2</sub>, dry powder, foam or water fog. DO NOT use water jets.

### **Environment**

WASTE DISPOSAL: Through authorized contractor to a licensed site. May be incinerated. Used product may be sent for reclamation.

SPILLAGE: Prevent entry into drains, sewers, and water courses. Soak up with absorbent material.

### **Handling**

Wear eye protection, impervious gloves (e.g. of PVC) and a plastic apron. Use in well ventilated area.

### **Storage**

No special precautions.

## TROUBLESHOOTING

Item numbers in parentheses refer to assembly drawing part numbers on page 9.

<b>Problem</b>	<b>Possible Cause</b>	<b>Remedy</b>
Threads will not engage the rivet nut	<ul style="list-style-type: none"> <li>▪ Wrong Mandrel Size</li> <li>▪ Worn or Broken Mandrel</li> <li>▪ RivetNut Thread Failure</li> </ul>	<ul style="list-style-type: none"> <li>▪ Measure rivetnut thread &amp; pitch and select appropriate mandrel</li> <li>▪ Replace Mandrel</li> <li>▪ Contact Rivetnut manufacture and inform them of thread pitch failure</li> </ul>
Tool will not pull down rivetnut	<ul style="list-style-type: none"> <li>▪ Check Rivetnut with capacity of tool</li> </ul>	<ul style="list-style-type: none"> <li>▪ This tool is capable of installing thin wall rivetnuts only.</li> <li>▪ The tool capacity is listed on the parts list.</li> </ul>
Trigger Failure	<ul style="list-style-type: none"> <li>▪ Pilot Valve Stem frozen or clogged</li> <li>▪ Loose rectangle nut in trigger stem.</li> </ul>	<ul style="list-style-type: none"> <li>▪ Perform Weekly Maintenance</li> <li>▪ Tighten rectangle nut (See trigger failure)</li> <li>▪ Replace if necessary</li> </ul>
Cannot release rivetnut	<ul style="list-style-type: none"> <li>▪ Threads of rivetnut stripped</li> <li>▪ Pressure too High</li> </ul>	<ul style="list-style-type: none"> <li>▪ Reduce Air pressure 80-90 psi max.</li> </ul>
Slow cycle	<ul style="list-style-type: none"> <li>▪ Lack of lubrication</li> <li>▪ Low air pressure</li> <li>▪ Build up of dirt inside tool</li> </ul>	<ul style="list-style-type: none"> <li>▪ Lubricate tool at air inlet point</li> <li>▪ Adjust air pressure to within specification</li> </ul>
Tool fails to operate	<ul style="list-style-type: none"> <li>▪ No air pressure</li> <li>▪ Damaged trigger valve</li> </ul>	<ul style="list-style-type: none"> <li>▪ Connect and adjust to within specification</li> <li>▪ Replace</li> <li>▪ Tighten</li> </ul>

A comprehensive tool service and repair program, for details contact your local area sales representative or call:

Industrial Rivet & Fastener Co  
 200 Paris Ave  
 Northvale, NJ 07647

## Warranty Statement:

Industrial Rivet & Fastener Co. Inc. and Zipp Tools (hereinafter "IRF"), hereby warrants to the initial retail customer and original distributor ("Warrantee") only that its products will be free from defects in material and workmanship for a period of 1 year from the purchase date, provided that the products are used in accordance with "IRF's" instructions as to maintenance, operation and use.

The said warranty does not extend to goods subjected to misuse, neglect, accident or improper installation or maintenance or which have been altered or repaired by anyone other than the seller or its authorized agents.

The warrantee's only remedy and IRF's only obligation in the event of a defect or failure in the products, is that IRF, at its sole option, repair, replace or rework the products, but in no case shall the cost of the foregoing exceed the invoice price of the products.

This warranty shall be void if any person seeking to make a claim for defective or failed products fails to notify IRF within 30 days of receipt of evidence that the product is defective or has failed, or if said person fails to provide IRF with such evidence as is reasonably requested concerning the effect or failure, including without limitation, evidence of the date of purchase and date of installation.

**This warranty is in lieu of all other warranties, expressed or implied, including merchantability, or fitness provided for herein. Under no circumstance shall IRF be liable for incidental or consequential damages arising from the defect or failure in its products.**

Seller's sole obligation under the foregoing warranty will be limited to, at Seller's option, repair or replacement of the tool (and shipping to the buyer with transportation charges paid to any place within the contiguous 48 states). Returned goods will be evaluated by our warranty repair department and a conclusion will be determined and classified as:

- a) Warranty Repair (free of charge)
- b) Abuse /Neglect (bench fee and/or hourly rate)
- c) Maintenance (Flat Fee)

If inspection by the seller of returned goods shows no breach of the forgoing warranty, Seller's regular conditioning charges (as stated above) apply. Upon this conclusion we will either repair the tool at no cost to you and return it postage paid, or call you to inform you of the repair cost. The repair will need to be approved in writing before any work is performed.

A comprehensive tool service and repair program, for details contact your local area sales representative or call:

Industrial Rivet & Fastener Co.  
200 Paris Ave  
Northvale, NJ 07647  
**1-800-BUY-RIVET**