

INSTRUCTION MANUAL

MODEL NO.:RK-401CR
14.4V CORDLESS RIVETER



NOTE

FUNCTIONAL GUIDES



(A)	EASY-CHANGED NOSEPIECES
(B)	EASY ACCESS REPLACEABLE CARBON BRUSHES FOR LONGER MOTOR LIFE
(C)	STORAGE FOR ANOTHER NOSEPIECES
(D)	FOLDABLE COVER DESIGN FOR EASY AND QUICK MANDREL REMOVAL. MANDREL COLLECTOR MEANS NO MORE MANDRELS ON FLOOR.
(E)	ERGONOMICAL DESIGNED HANDLE PROVIDES A WELL-BALANCE
(F)	EASY ATTACHED SLIDING BATTERY SYSTEM
(G)	HIGH CAPACITY LI-ION BATTERY PACK DELIVERS LONGER RUN-TIME

WARNING! "READ ALL INSTRUCTIONS" Always observe the safety regulations applicable in your country to reduce the risk of fire, electric shock and personal injury. Understand the following safety instructions before attempting to operate this product. Always wear eye protection when working with power tools. Keep these instructions in a safe place.

SAVE THESE INSTRUCTIONS

General Safety Rules

Work Area Safety

- **Keep your work area clean and well lit.** Cluttered benches and dark areas invite accidents.
- **Do not operate power tools in explosive atmospheres, such as in the presence of flammable liquids, gases, or dust.** Power tools create sparks which may ignite the dust or fumes.
- **Keep bystanders, children, and visitors away while operating a power tool.** Distractions can cause you to lose control.

Personal Safety

- **Stay alert, watch what you are doing and use common sense when operating a power tool. Do not use tool while tired or under the influence of drugs, alcohol, or medication.** A moment of inattention while operating power tools may result in serious personal injury.
- **Dress properly. Do not wear loose clothing or jewelry. Contain long hair. Keep your hair, clothing, and gloves away from moving parts.** Loose clothes, jewelry, or long hair can be caught in moving parts.
- **Do not overreach. Keep proper footing and balance at all times.** Proper footing and balance enables better control on the tool in unexpected situations.

- **Use safety equipment. Always wear eye protection.** Dust mask, non-skid safety shoes, hard hat, or hearing protection must be used for appropriate conditions.

Tool Use and Care

- **Use clamps or other practical ways to secure and support the work piece to a stable platform.** Holding the work piece by hand or against your body is unstable and may lead to loss of control.
- **Do not force tools. Use the correct tool for your application.** The correct tool will do the job better and safer at the rate for which it is designed.
- **Do not use tool if switch does not turn it on or off.** Any tool that cannot be controlled with the switch is dangerous and must be repaired.
- **Store idle tools out of reach of children and other untrained persons.** Tools are dangerous in the hands of untrained users.
- **Check for misalignment or binding of moving parts, breakage of parts, and any other condition that may affect the tool operation. If damaged, have the tool serviced before using.** Many accidents are caused by poorly maintained tools.

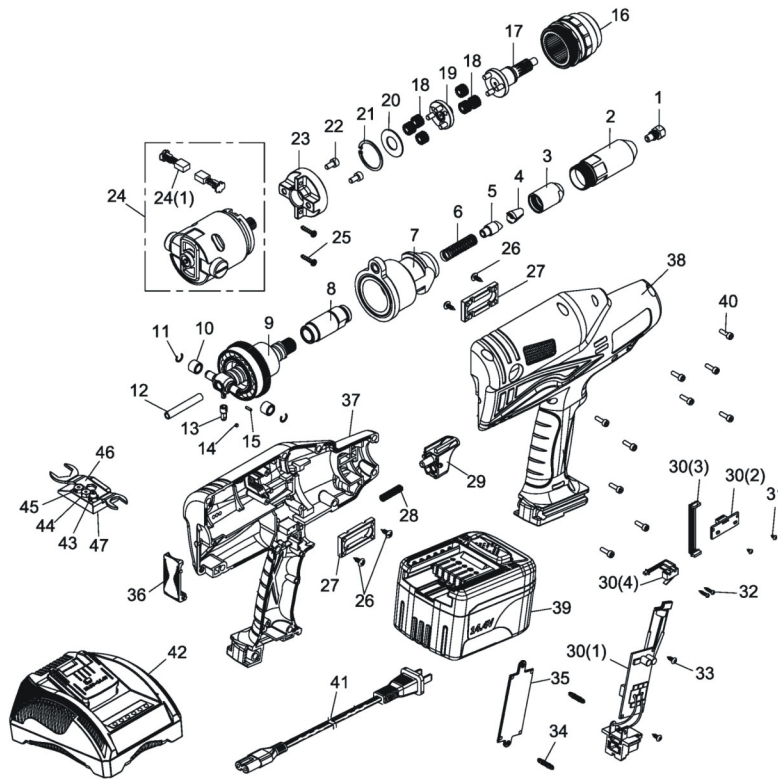

TECHNICAL DATA	Rivets Capacity	: 2.4mm~4.8mm(all material)
	Pulling mechanism	: Ball screw
	Pulling force	: 1870lbs(8330N)
	Weight	: 4.8lbs(2.2kg)
	Battery pack	: 14.4V / Li-ion / 3.0A.h
	Stroke Length	: 0.79"(20mm)
	Pulling time per unit	: 1sec

PARTS LIST

Index	Part#	Description	Index	Part#	Description	Index	Part#	Description
1	CCR920BS-01	Nosepiece 3/16"(4.8mm)	17	CCR920BS-17	Gear Cage Assembly	34	CCR920BS-34	Interval pillar (2)
2	CCR920BS-02	Head	18	CCR920BS-18	Planet Gear (6)	35	CCR920BS-35	Plates
3	CCR920BS-03	Jaw-Housing	19	CCR920BS-19	Gear Cage Assembly	36	CCR920BS-36	Collector Lid
4	CCR920BS-04	Jaws (two-parts) (2)	20	CCR920BS-20	Washer	37	CCR920BS-37	Housing Lower Cover Assembly
5	CCR920BS-05	Jaw-Pusher	21	CCR920BS-21	Snap Ring (RTW-26)	38	CCR920BS-38	Housing Upper Cover Assembly
6	CCR920BS-06	Spring	22	CCR920BS-22	Screw (M4x8) (2)	39	CCR920BS-39	Battery Pack
7	CCR920BS-07	Transmission Housing Assembly	23	CCR920BS-23	Motor Holder	40	CCR920BS-40	Screw (M3x10L) (10)
8	CCR920BS-08	Jaw Housing Coupler	24	CCR920BS-24	Motor Assembly	41	CCR920BS-41	AC Wire
9	CCR920BS-09	Ball Screw Assembly	25	CCR920BS-25	Screw (φ3x14L) (2)	42	CCR920BS-42	Battery Charger
10	CCR920BS-10	Bushing (2)	26	CCR920BS-26	Screw (φ3x10L) (4)	43	CCR920BS-43	Nosepiece 3/32" (2.4mm)
11	CCR920BS-11	Snap Ring (2)	27	CCR920BS-27	Steel Track (2)	44	CCR920BS-44	Nosepiece 1/8" (3.2mm)
12	CCR920BS-12	Tube	28	CCR920BS-28	Spring	45	CCR920BS-45	Nosepiece 5/32" (4.0mm)
13	CCR920BS-13	Magnet Holder	29	CCR920BS-29	Trigger	46	CCR920BS-46	3 in 1 Wrench
14	CCR920BS-14	Magnet	30	CCR920BS-30	Circuit Board Assembly	47	CCR920BS-47	Wrench Place
15	CCR920BS-15	Spring Pin (φ1.5x6)	31	CCR920BS-31	Screw (φ2x6L) (2)			
16	CCR920BS-16	Gear Box Assembly	32	CCR920BS-32	Screw (φ2x10L) (2)			
			33	CCR920BS-33	Screw (φ3x8L) (2)			

- **Use only accessories that are recommended by the manufacturer for your model.** Accessories that may be suitable for one tool, may become hazardous when used on another tool.

Service

- **Tool service must be performed only by qualified repair personnel.** Service or maintenance performed by unqualified personnel could result in a risk of injury.
- **When servicing a tool, use only identical replacement parts. Follow instructions in the Maintenance section of this manual.** Use of unauthorized parts or failure to follow maintenance instructions may create a risk of electric shock or injury.

Additional Safety Rules for Cordless Riveter

Battery Charger

- Caution: To reduce risk of injury, charge only the authorized batteries. Other types of battery may burst, causing personal injury and damage.
- Before using battery charger, read all instructions and cautionary markings on batteries, chargers and products using batteries.
- Do not allow anything to cover or clog the charger vents.
- Do not expose charger to rain, snow or wet conditions.
- To reduce the risk of damage to electric plug and cord, pull by plug rather than cord when disconnecting charger.
- Use of an attachment not recommended or sold by the manufacturer may result in a risk of fire, electric shock, or injury to persons.

- Make sure cord for charger is located so that it will not be stepped on, tripped on, tripped over, or otherwise subjected to damage or stress.
- Do not abuse the power cord. Never use the cord to carry the charger. Keep cord away from heat, oil, water, sharp edges, or moving parts. Replace damaged cords immediately.
- Do not operate charger if it has been damaged in any way, take it to a qualified service center for repair.
- To reduce risk of electric shock, unplug charger from outlet before attempting any maintenance or cleaning. Turning off controls will not reduce this risk.
- Do not disassemble charger or battery cartridge, take it to a qualified service center when repair is required. Incorrect reassembly may result in a risk of electric shock or fire.

Battery Pack

- Do not charge battery pack when temperature is below 0°C (32°F) or above 40°C(104°F).
- Do not attempt to use a step-down transformer, an engine generator or DC power receptacle.
- Do not short the battery pack: Do not touch the terminals with any conductive material. Avoid storing battery cartridge in a container with other metal objects such as nails, coins, paper clips, etc.
- Do not expose battery cartridge to water or rain. A battery short can cause large current flow, overheating, possibly burns and even a break-down.

NOTE: Please fill out and send in the registration card within 7 days of purchase.

Please record the following information to expedite warranty work or parts order:

Model No. _____

Description Cordless 14.4V Riveter

Serial No. _____

Purchase Date: _____

Purchased From: _____

Address of Retailer: _____

Please affix original or copy of sales receipt here to facilitate warranty works.

MAINTENANCE

- Maintenance of the DC motor. Exercise due care to ensure the motor does not burn out due to overloading.
- Do not allow brake-fluids, gasoline, petroleum-based products, penetrating oils, etc. To come in contact with plastic parts. They contain chemicals that can damage, weaken or destroy the tool and battery housing.
- Repairs should only be done by a qualified service technician using identical parts to ensure the safe and effective use of this product.
- Always ensure that the machine is switched off and the battery cartridge is removed before carrying out any work on the machine.
- To maintain product safety and reliability, repairs, maintenance or adjustment should be carried out by an authorized service center.

SPECIFICATIONS

Model: CCR920BS

Voltage:	14.4 VDC
Capacity:	3/32"(2.4mm) ~3/16"(4.8mm) all material
Stroke length:	0.79"(20mm)
Traction power:	2,900 lbs(1318kg)
Weight with Li-ion battery pack:	4.8 lbs (2.2kg)
Battery pack:	14.4V / Li-ion / 3.0A.h
Charge Time:	approx. 60 mins
Charger accepted:	Ni-MH/ Li-ion

WARRANTY

This product carries a one-year warranty. We will repair, without charge, any defects due to faulty material or workmanship. Before you send back the product please first call your dealer or the local service center. Experience has shown that over 90% of the problems can be resolved over the phone; saving much time and money for both parties. If a return is necessary, simply return 1. only the part in question; 2. copy of original sales receipt; and 3. freight prepaid to an authorized warranty center. This warranty does not apply to

- accessories
- damage caused where repairs have been made or attempted by others
- damage due to abuse, misuse, neglect, normal wear and tear, alteration or modification
- products used as a rental unit

In no event shall the manufacture be liable for any incidental or consequential damages.

- Do not store the machine and battery pack in locations where the temperature may reach or exceed 50°C(122°F).
- Do not incinerate the battery pack even if it is severely damaged or completely worn out. The battery pack can explode in a fire.
- Be careful not to drop, shake, or strike the battery.
- Do not charge inside a box or container of any kind. The battery must be placed in a well ventilated area during charging.
- Do not dispose of battery packs into household waste, fire or water. Battery packs should be collected, recycled or disposed of in an environmentally-friendly manner. Call the authorized warranty centers for places to dispose of damaged or inoperable batteries.

FUNCTIONAL DESCRIPTION

1. Collector Lid

Collect the rivets are cut in the collect lid temporarily.

2. Easy Brush Access Cover

The cover allows the user to access the carbon brush for replacement.

3. Li-ion Battery Pack

This battery provides electrical power to the motor. Please charge it according to the charging instruction listed in this manual.



Figure 1

ASSEMBLY

Check for damage to the tool; parts or accessories which may have occurred during transport. Take the time to thoroughly read and understand this manual prior to operation.

This tool kit contains:

- 1 14.4V cordless Riveter (include 1 nosepiece)
- 1 or 2 quick charge batteries
- 1 one-hour quick charger
- 1 power cord
- 1 instruction manual
- 1 3 in 1 wrench
- 3 nose pieces
- 1 spanner holder

OPERATIONS

Attaching or Removing Battery Pack

1. To connect battery, line up the tracks and attach the battery pack. Slide toward the battery pack until it locks into positions with a click.

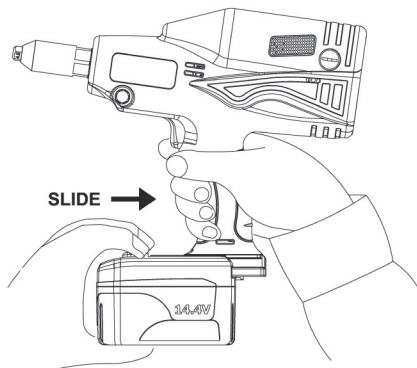

2. To remove the battery pack, push on the RED button on the top and release the battery pack.

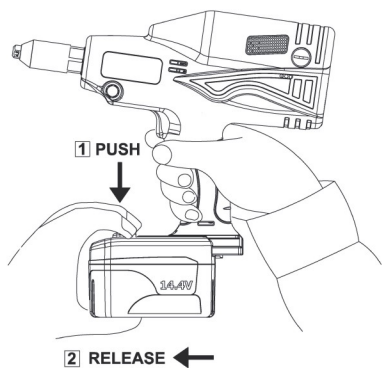

This product had been carefully inspected prior to leaving the factory. It should provide you with years of satisfying service under normal operating conditions. Do not, however, force the tool to perform outside its design parameters. Such usage will void the warranty.

WARNING! Always wear safety glasses or face-shields when operating this product. Failure to do so can result in dust, shavings or loose particles being thrown into your eyes.

1. Slide battery into the bottom of the housing handle until a click sound occurs. Do not force battery as it should slide easily into place with nominal force. Any difficulty doing so would indicate an incorrect alignment.
2. When attaching the battery pack, a long beep sound will occur for 2 seconds that indicates the electric currents are connected between the battery and the tool. Ready to work.
3. Before operating, check if the diameter of the nose piece collates with the diameter of the rivet.



LAMP INDICATIONS



Red Lit

Charger is plugged into the AC outlet. Ready to charge.



Yellow Flashing

- (1) When the temperature of the battery is too low ($<0^{\circ}\text{C}$ ($<32^{\circ}\text{F}$)), it is in a trickle charge mode until the temperature of the battery goes up to over 0°C ($<32^{\circ}\text{F}$). The lamp will change from the Yellow Flashing to Green Flashing automatically and start to charge. (If after 70 minutes, the lamp changes from yellow flashing to yellow lit, consult an authorized dealer.)
- (2) When the temperature of the battery is too high ($>40^{\circ}\text{C}$ (104°F)), it is in a trickle charge mode until the temperature of the battery drops to under 40°C (104°F). The lamp will change from the Yellow Flashing to Green Flashing automatically and start to charge. (If after 70 minutes, the lamp changes from yellow flashing to yellow lit, consult an authorized dealer.)
- (3) When the voltage of the battery is too low (below 10.8 voltage), it is in a trickle charge mode until the voltage of the battery reaches to the standard value. The lamp will change from the Yellow Flashing to Green Flashing automatically and start to charge. (If after 20 minutes, the lamp changes from yellow flashing to yellow lit, consult an authorized dealer.)



Yellow Lit

The battery and the charger are not connected. If the yellow lit still on after trying re-attach the battery, consult the an authorized dealer.



Green Flashing

Now start charging



Green Flashing

Battery is approximately 50% charged.



Green Flashing

Battery is approximately 80% charged.



Green Lit

Charging is complete. (Fully charged.)

Charging the battery - for Li-ion/ Ni-MH battery

[NOTE]

- When charging a cool battery pack (below 0°C(32°F)) in a warm place, leave the battery pack at the place and wait for more than one hour to warm up the battery to the level of the ambient temperature. Otherwise battery pack may not be fully charged.
- Cool down the charger when charging more than two battery packs consecutively.
- Do not insert your fingers/ nails into contact hole, when holding charger or any other occasions.

1.Place charger in a relatively cool and well-ventilated area.

2.Plug charger into the AC outlet.

CAUTION: Ensure that the power source to be utilized conforms to the power requirement specified on the product nameplate.

3.Turn the battery up-side-down and slide the battery into charger while keeping the alignment marks line up. Slide the forward in the direction of the arrow. Do not force battery as it should slide easily into place with nominal force. Any difficulty doing so would indicate an incorrect alignment.



4. If the power lamp (red) does not light immediately or goes out soon after the charger is plugged in, consult an authorized dealer.

5. During charging, the charging lamp (green) will start flashing. When charging is completed, an internal electronic switch will automatically be triggered to prevent overcharging.

- Charging will not start if the battery pack is warm. For example, immediately after heavy-duty operation. The yellow standby lamp will be flashing until the battery cools down.

6. If the temperature of the battery pack is 0°C or less, charging takes longer to fully charge the battery pack than the standard charging time. Even when the battery is fully charged, it will have approximately 50% of the power of a fully charged battery at normal operation temperature.

7. Once the battery is fully charged, the green lamp will be lit to indicate the gone into a trickle charge mode.

Ni-MH Battery Pack

[NOTE]

When you charge the battery pack for the first time, or after prolonged storage, charge it for about 24 hours to bring the battery up to full capacity.

Li-ion Battery Pack

[NOTE]

Your battery pack is not fully charged at the time of purchase. Be sure to charge the battery before first use.

4.Put the rivet into the nose piece and plug into the work piece then depress the trigger. Do not release the trigger until the rivet is cut.

[NOTE]

If to release the trigger before the rivet being cut, the rivet will back to the original place.

CAUTION:

After releasing the trigger, **MUST** have one second interval before next operation.

5.When the rivet is cut, either move forward the tool to let the rivet out or move backward to let the rivet fall into the collect box.

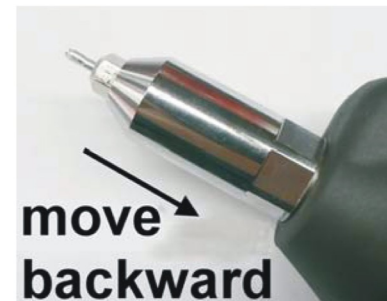
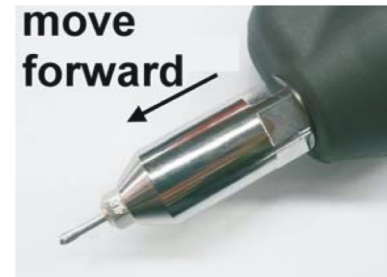

6.When the collect box is almost full, push it out and clean it.

7.When pushing the trigger, if four short beep sounds occur that indicates the battery would be out of battery soon. Change the battery pack immediately.



Foldable cover design for easy and quick mandrel removal. Mandrel collector means no more mandrels on floor.

CAUTION:

The battery will be auto shut off when working with an unusual rivet during the riveting process. If this happens, wait for five seconds and then depress "RESET", remove the battery and reattach again.

Nose Piece Replacement:

1. Use the wrench or the 3 in 1 wrench to disassemble the nose piece and replace the size of the desired nose piece. Then, tighten it by either wrench.

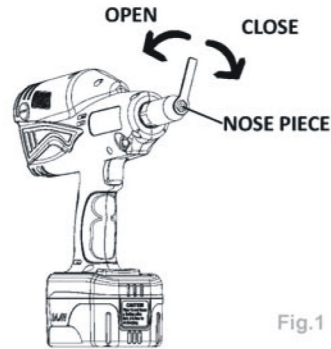

Maintenance/ Cleaness

1. Use the big end of the 3 in 1 wrench to disassemble the head.

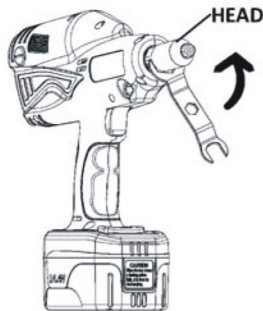

2. Use the small end of the 3 in 1 wrench to disassemble the jaws housing and take out the jaws and the jaws pusher. Clean the dusts by blow guns or cloth. •

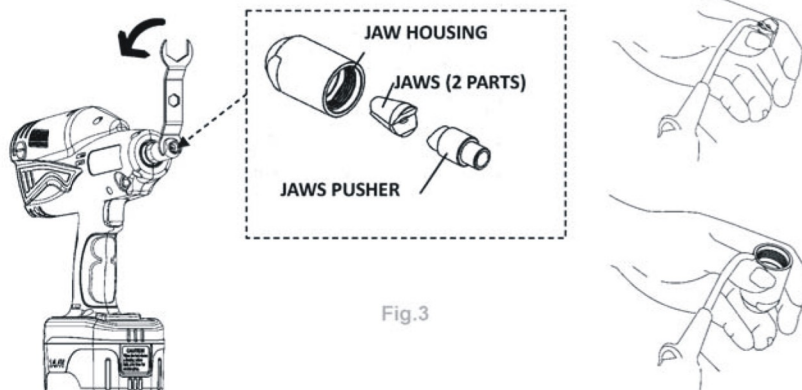

3. When assembling, install the jaws into the jaws housing, and then install the jaws pusher by aligning the ramp of the jaws. Next, tighten the jaws housing then the nose head back to the housing.

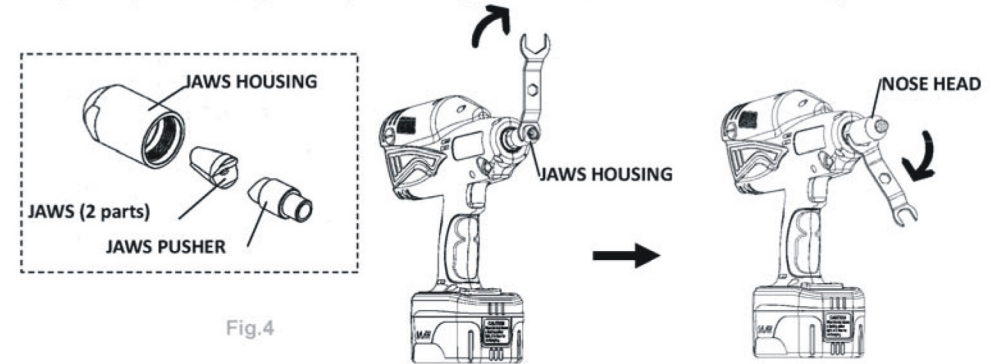

Battery Pack - Li-ion Battery Pack

1. For Optimum battery life, store the Li-ion battery pack following use without charging it.
2. Do not charge battery when ambient temperature is below 0°C(32°F) or above 40°C(104°F). If the battery pack is used when the battery temperature is below 0°C (32°F), the tool may fail to function properly.

Battery Pack Life

The rechargeable batteries have a limited life. If the operation time becomes extremely short after recharging, replace the battery pack with a new one.

Battery Recycling

The batteries must be recycled or disposed properly.